

DISTIL'ER 70 - 75 CL

PREMIUM



DISTIL'ER draws inspiration from the dispensary bottles of yesteryear. Its sharp-angled punt with rounded edges innovates and is reflected in the shoulder's well-balanced symmetry. This distinctive design feature makes it a real stand-out bottle. Its large decorative surface makes it easy for anyone to customize. Its moderate weight and various finishes (flat or screw) add to its many strengths. DISTIL'ER boasts a design with character and a distinct style, giving the impression of having been handcrafted.

DISTIL'ER se inspira en las botellas tradicionales. Su puntada, con su ángulo redondeado, innova y responde con un armonioso juego de simetría en el hombro. Esta característica de diseño la hace muy diferente. Con una gran superficie decorativa, ofrece a todo el mundo la posibilidad de personalizarla fácilmente. Su peso razonable y sus diferentes cierres (anillo plano o de rosca) se suman a sus muchas ventajas. DISTIL'ER muestra un diseño de carácter, con un cierto carácter y un espíritu «artesanal».

TECHNICAL FEATURES ESPECIFICACIONES TÉCNICAS

Capacity Capacidad	23.67 oz 70 cl	23.67 oz 70 cl	25.36 oz 75 cl	25.36 oz 75 cl
Reference Referencia	5394	5394	5395	5395
Finish Boca	Plate	GPI 400/33	Plate	GPI 400/33
Weight Peso	22.57 oz 640 g	22.54 oz 639 g	22.57 oz 640 g	22.54 oz 639 g
Overall height Altura total	9.21 in 234 mm	9.26 in 235,2 mm	9.21 in 234 mm	9.26 in 235,2 mm
Maxi section Diámetro máximo sección	3.46 in 87,9 mm	3.46 in 87,9 mm	3.56 in 90,3 mm	3.56 in 90,3 mm
Entrance bore diameter Diámetro de entrada	0.85 in 21,5 mm	0.85 in 21,5 mm	0.85 in 21,5 mm	0.85 in 21,5 mm
Fill height Nivel de llenado	2.76 in 70 mm	2.8 in 71 mm	2.76 in 70 mm	2.8 in 71 mm
Quality Criterio de calidad	Standard + Estandard +	Standard + Estandard +	Standard + Estandard +	Standard + Estandard +
Punt height Altura picadura	0.87 in 22 mm	0.87 in 22 mm	0.87 in 22 mm	0.87 in 22 mm
Glass color Color de vidrio	○ Extra White Flint Extra Blanco	○ Extra White Flint Extra Blanco	○ Extra White Flint Extra Blanco	○ Extra White Flint Extra Blanco

PACKING EMBALAJE

Number of bottles per layer Número de botellas por capa	143	143	120	120
Number of layers Número de capas	8	8	8	8
Number of bottles per pallet Número de botellas por palet	1144	1144	960	960
Pallet gross weight Peso total por palet	781 kg	781 kg	661 kg	661 kg
Overall height Altura total	2,05 m	2,05 m	2,05 m	2,05 m

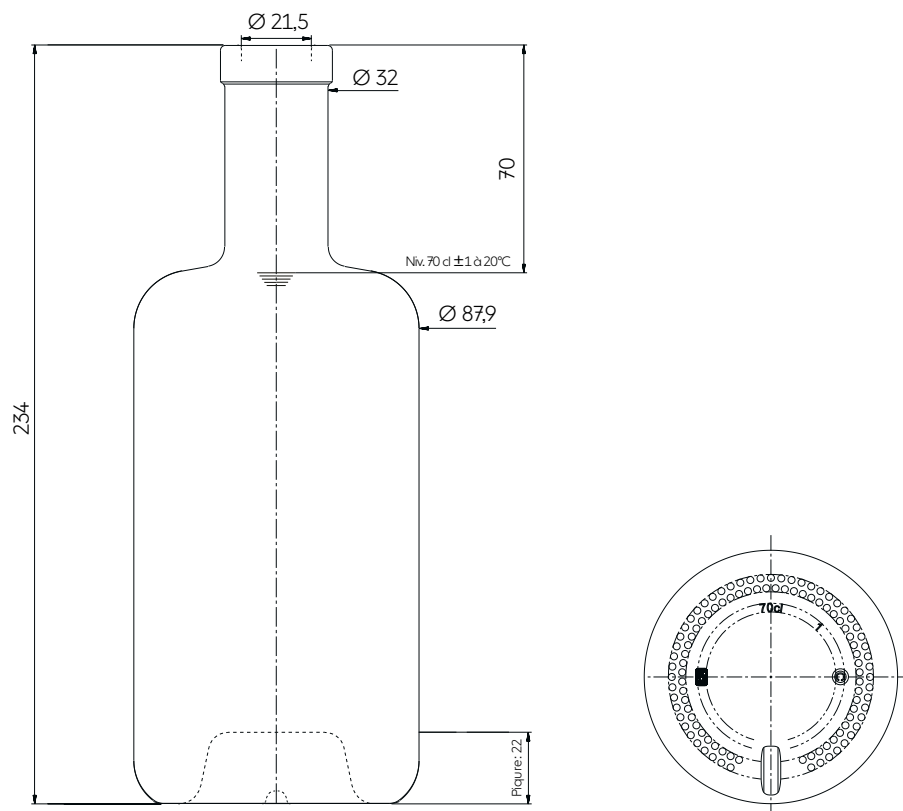

70 cl
Modèle déposé « Design Saverglass »
Saverglass Registered Design